

MAIN GEAR AND CHAIN GEAR ASSEMBLY

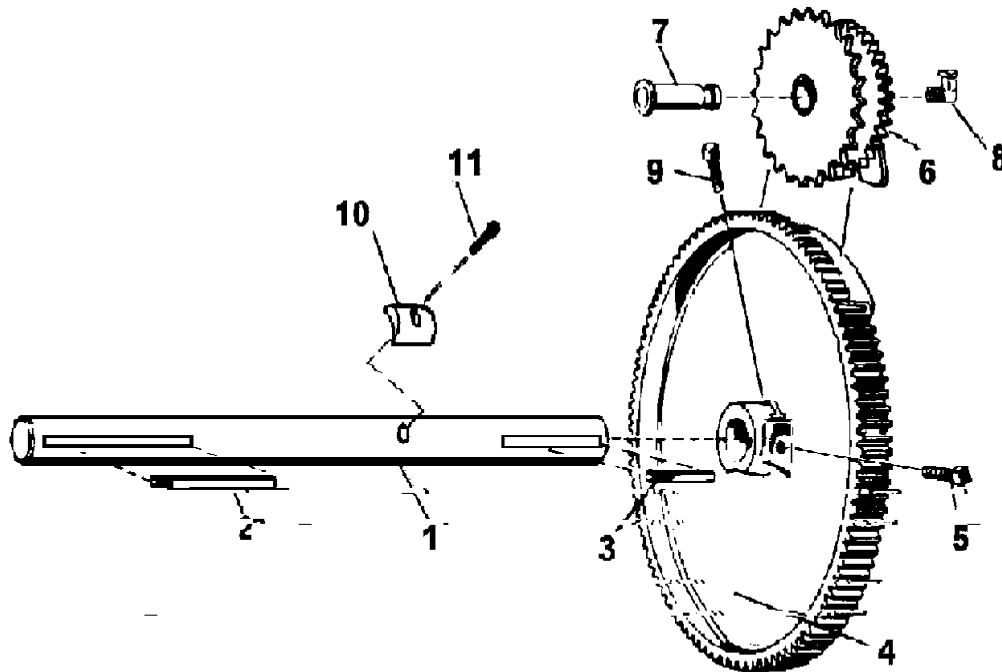

Index	Part	Qty	Index	Part	Qty
1	012182 Main Shaft	1	6	020245 Chain Gear Assembly	1
2	083057 Key, Main Cam	1	7	081032 Stud, Chain Gear Assembly	1
3	083074 Key, Main Gear	1	8	100087 Oil-Cup 90°	1
4	020004 Main Gear	1	9	100128 Screw, Set Square Head Knurled Cup Point	1
5	100127 Screw, Set Square Head Knurled Cup Point	1	10	009137 Brake Cam	

NOTE: When Changing either the Main Gear or Chain Gear Assembly, make sure the timing tooth on both parts are not worn.
If either timing tooth is not square like other teeth then both gears *must* be replaced.